

Copyright. All information furnished within this document, electronic file or design correspondence is the property of Den Hartog industries, Inc. and shall not be used, disclosed to others or copied without the expressed written consent of Den Hartog Industries, Inc.

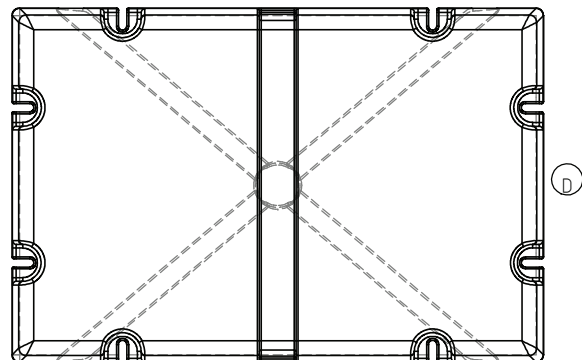
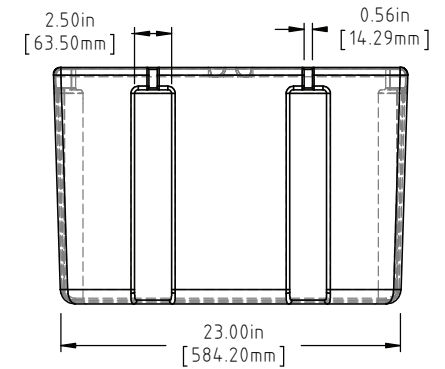
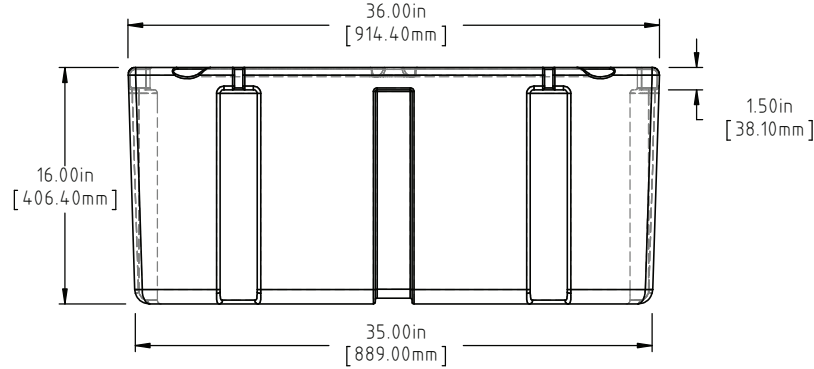
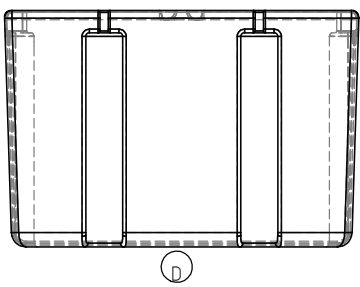
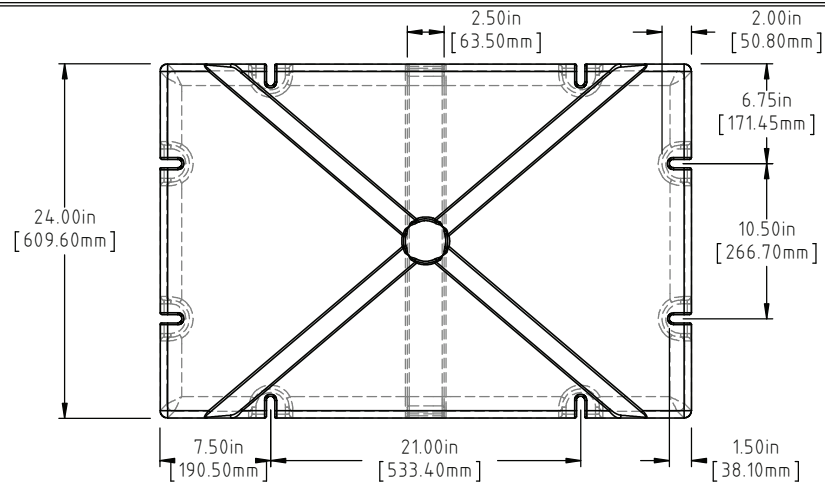

D	BOTTOM AND SIDE VIEWS ADDED TO PRINT	ADH 12/4/14	2971
C	30 LBS WAS 29 LBS, 436 LBS WAS 424 LBS	ADH 6/18/12	2420
B	METRIC DIMENSIONS ADDED	ADH 6/12/08	1685
A	ADDED BUOYANCY	GWC 1/3/07	
A	CHANGE WEIGHT FF WAS 32	GWC 1/3/07	
1	CHANGE WEIGHT	11/16/94	
REV	DESCRIPTION	BY / DATE	CCN

DRAWN / DATE DEH 10/15/93	MATERIAL POLYETHYLENE
APPRD. / DATE ADH 11/5/07	
SHOT WEIGHT: 21 LBS.(9.07 KG.)	NOTES: (A)(C) 1.) AF 21 LBS.(9.07 KG.) 2.) FF 30 LBS.(13.61 KG.) 3.) 0.150in (3.81mm) NOM. WALL
SHIPPING WEIGHT: SEE NOTES	
FINISH:	

(C) (A) NOTE: BUOYANCY 436 LBS.(197.77 KG.)



**Den Hartog**  
INDUSTRIES, INC.

Ace Roto-Mold Injection Molding Blow Molding Sowjoy  
4010 HOSPERS DRIVE S. BOX 425, HOSPERS, IOWA 51238-0425

ALL DIMENSIONS ARE IN DECIMAL INCHES  
TOLERANCES UNLESS OTHERWISE SPECIFIED  
POLYETHYLENE METAL  
DECIMAL ± .125"  
FRACTION ± 1/4"  
ANGLE ± 1°  
±1% @ 68°F

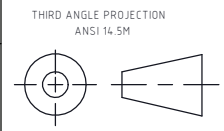

DESCRIPTION	24 X 36 X 16 FLOAT	
SCALE	N.S.	PART NO. 2436-16