

Copyright. All information furnished within this document, electronic file or design correspondence is the property of Den Hartog Industries, Inc. and shall not be used, disclosed to others or copied without the expressed written consent of Den Hartog Industries, Inc.

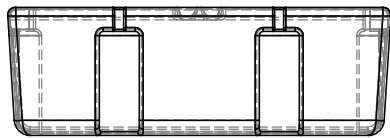

D

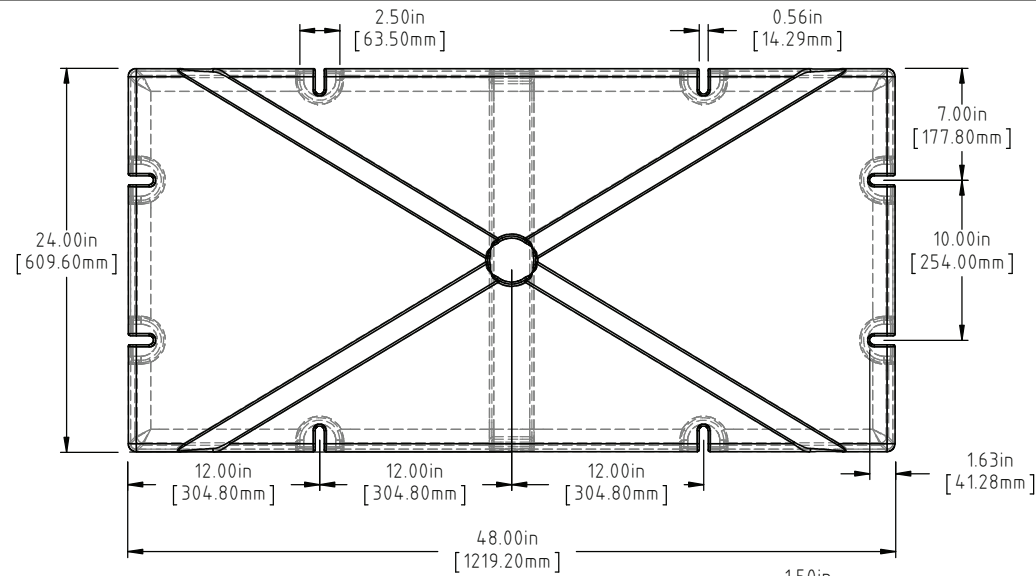
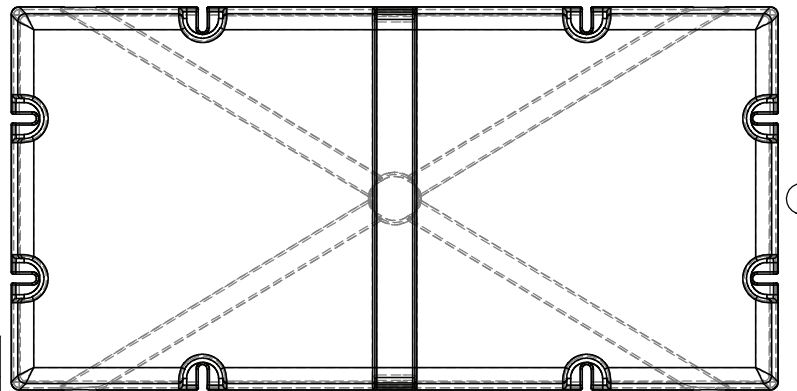
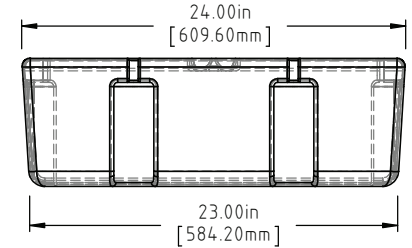
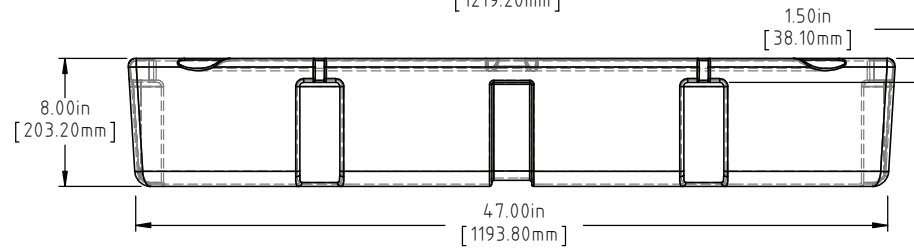

D

NOTE: BUOYANCY IS 288 LBS.(130.63 KG)

D	BOTTOM AND SIDE VIEWS ADDED TO PRINT	ADH 12/4/14	2971
C	27 LBS WAS 26 LBS, 288 LBS WAS 285 LBS	ADH 6/20/12	2420
B	METRIC DIMENSIONS ADDED	ADH 6/12/08	1685
A	ADD BUOYANCY	GWC 1/3/07	
A	CHANGE WEIGHTS, AF WAS 20	GWC 1/3/07	
REV	DESCRIPTION	BY / DATE	CCN

DRAWN / DATE REH 12/24/98	MATERIAL POLYETHYLENE
APPRD. / DATE ADH 11/5/07	



**Den Hartog**  
INDUSTRIES, INC.

Ace Roto-Mold Injection Molding Blow Molding Sowjoy

4010 HOSPERS DRIVE S. BOX 425, HOSPERS, IOWA 51238-0425

ALL DIMENSIONS ARE IN DECIMAL INCHES  
TOLERANCES UNLESS OTHERWISE SPECIFIED  
POLYETHYLENE  
±1% @ 68°F

THIRD ANGLE PROJECTION  
ANSI 14.5M

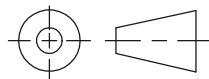

SHOT WEIGHT:  
21.00 LBS. (9.53 KG.)  
SHIPPING WEIGHT:  
SEE NOTES  
FINISH:

NOTES: (A) (C)  
1.) AF 21.00 LBS. (9.53 KG.)  
2.) FF 27.00 LBS. (12.25 KG.)  
3.) 0.150 IN (3.81 mm) NOM. WALL

DESCRIPTION  
24 X 48 X 08 FLOAT

SCALE  
N.S.

PART NO.  
2448-08