

© DEN HARTOG INDUSTRIES, INC.

Copyright. All information furnished within this document, electronic file or design correspondence is the property of Den Hartog Industries, Inc. and shall not be used, disclosed to others or copied without the expressed written consent of Den Hartog Industries, Inc.

3672-24

D

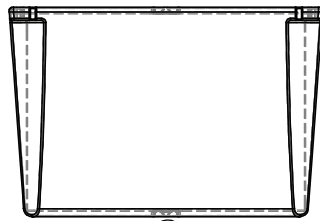
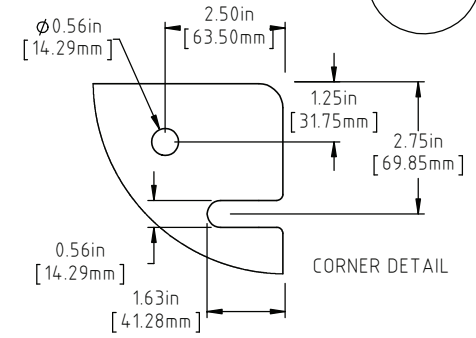
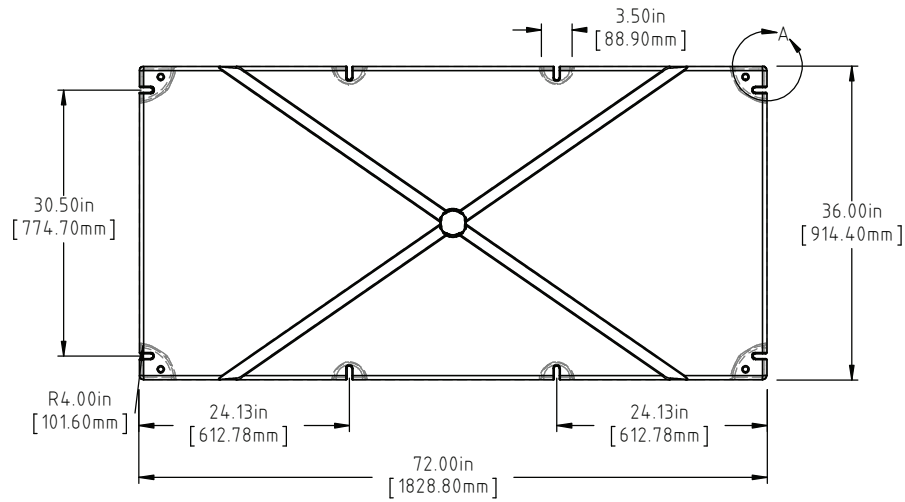

D

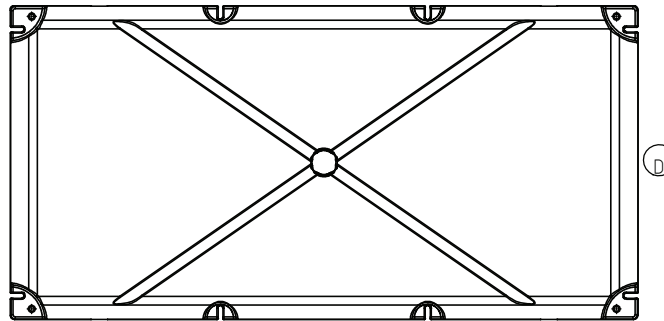
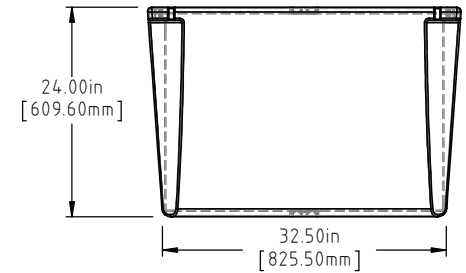
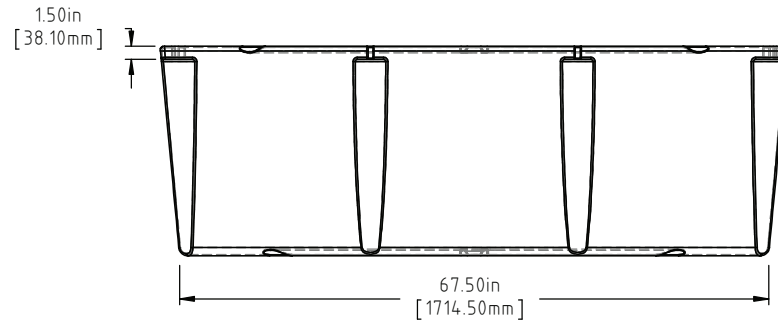

D

A C

NOTE: BUOYANCY 1951.00 LBS.(884.96 KG.)

D	BOTTOM/SIDE VIEWS ADDED TO PRINT.	ADH 12/4/14	2971
C	99 LBS WAS 94 LBS, 1951 LBS WAS 1915 LBS	ADH 6/22/12	2420
B	METRIC DIMENSIONS ADDED	ADH 6/17/08	1685
A	ADD BUOYANCY NOTE	GWC 1/9/07	
A	CHANGE WEIGHT FF WAS 105	GWC 1/9/07	
REV	DESCRIPTION	BY / DATE	CCN

DRAWN / DATE REH 9/9/98	MATERIAL POLYETHYLENE
APPRD. / DATE ADH 11/5/07	

ALL DIMENSIONS ARE IN DECIMAL INCHES TOLERANCES UNLESS OTHERWISE SPECIFIED	
POLYETHYLENE ±1% @ 68°F	METAL DECIMAL ± .125" FRACTION ± 1/4" ANGLE ± 1°

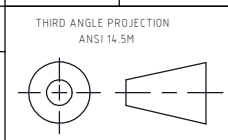

SHOT WEIGHT: 61 LBS.(27.67 KG.)	NOTES: A C 1.) AF 61 LBS.(27.67 KG.) 2.) FF 99 LBS.(44.91 KG.) 3.) 0.150in (3.81mm) NOM. WALL
SHIPPING WEIGHT: SEE NOTES	
FINISH:	

DESCRIPTION 36 X 72 X 24 FLOAT
SCALE N.S.
PART NO. 3672-24



**Den Hartog**  
INDUSTRIES, INC.

Ace Roto-Mold Injection Molding Blow Molding Sowjoy

4010 HOSPERS DRIVE S. BOX 425, HOSPERS, IOWA 51238-0425