

© DEN HARTOG INDUSTRIES, INC.

Copyright. All information furnished within this document, electronic file or design correspondence is the property of Den Hartog industries, Inc. and shall not be used, disclosed to others or copied without the expressed written consent of Den Hartog Industries, Inc.

3696-12

B

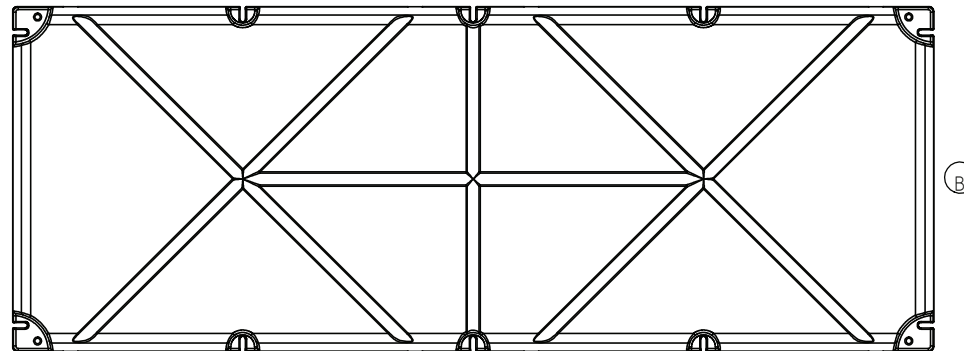
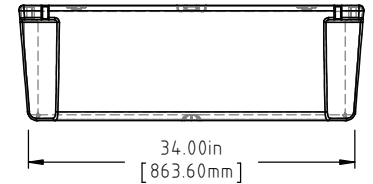
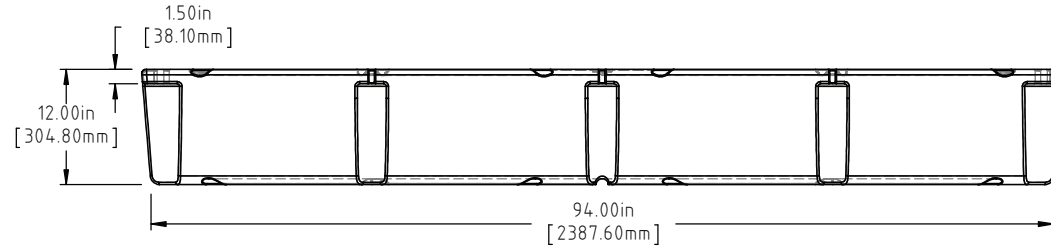
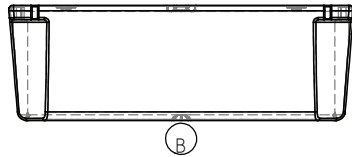
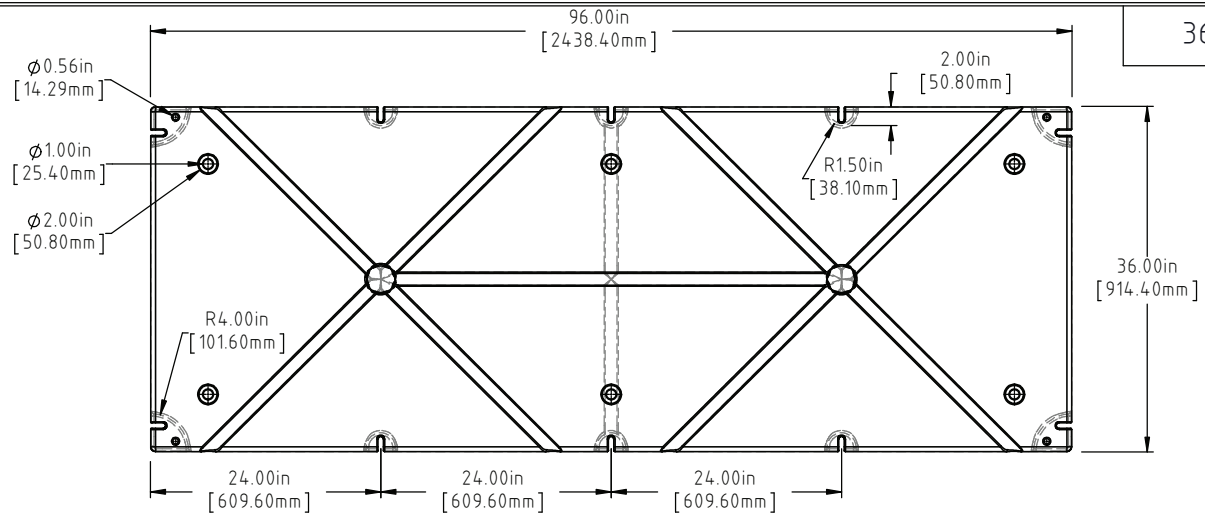

NOTE: BUOYANCY 1331.00 LBS.(603.73 KG.)

B	BOTTOM AND SIDE VIEWS ADDED TO PRINT	ADH 12/4/14	2971	DRAWN / DATE DHJ 1/10/06	MATERIAL POLYETHYLENE
A	90 LBS WAS 89, BUOYANCY NOTE ADDED	ADH 6/22/12	2420	APPRD. / DATE ADH 11/5/07	
REV	DESCRIPTION	BY / DATE	CCN		
ALL DIMENSIONS ARE IN DECIMAL INCHES TOLERANCES UNLESS OTHERWISE SPECIFIED		THIRD ANGLE PROJECTION ANSI 14.5M		SHOT WEIGHT: 65 LBS.(29.48 KG.)	NOTES: (A) 1.) AF 65 LBS.(29.48 KG.) 2.) FF 90 LBS.(40.82 KG.)
POLYETHYLENE ±1% @ 68°F		METAL DECIMAL ± .125" FRACTION ± 1/4" ANGLE ± 1°		SHIPPING WEIGHT: SEE NOTES	
		FINISH:			



Den Hartog
INDUSTRIES, INC.

Ace Roto-Mold Injection Molding Blow Molding Sowjoy

4010 HOSPERS DRIVE S. BOX 425, HOSPERS, IOWA 51238-0425

DESCRIPTION	36 X 96 X 12 FLOAT	
SCALE	N.S.	PART NO. 3696-12