

© DEN HARTOG INDUSTRIES, INC.

Copyright. All information furnished within this document, electronic file or design correspondence is the property of Den Hartog Industries, Inc. and shall not be used, disclosed to others or copied without the expressed written consent of Den Hartog Industries, Inc.

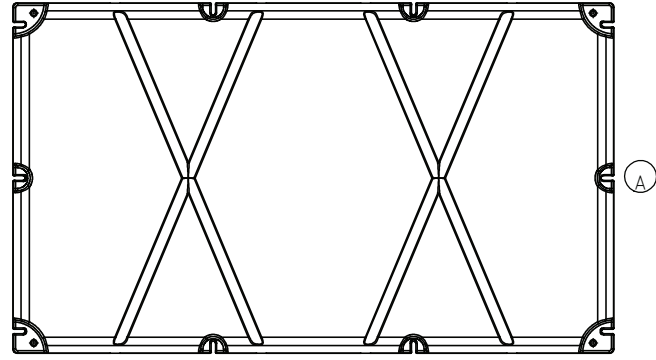
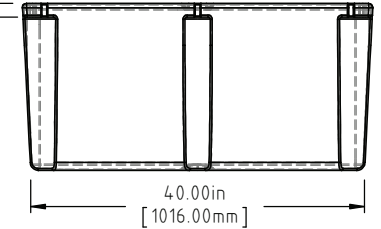
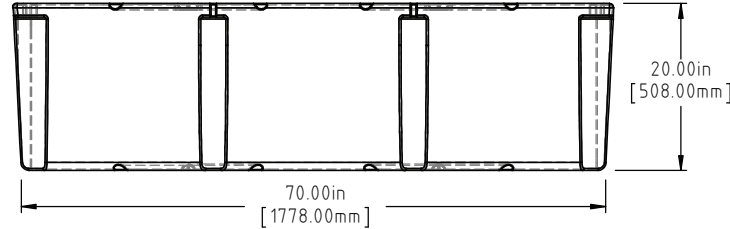
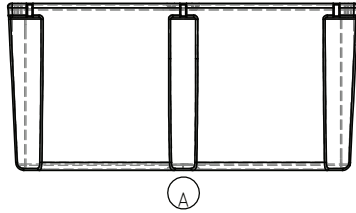
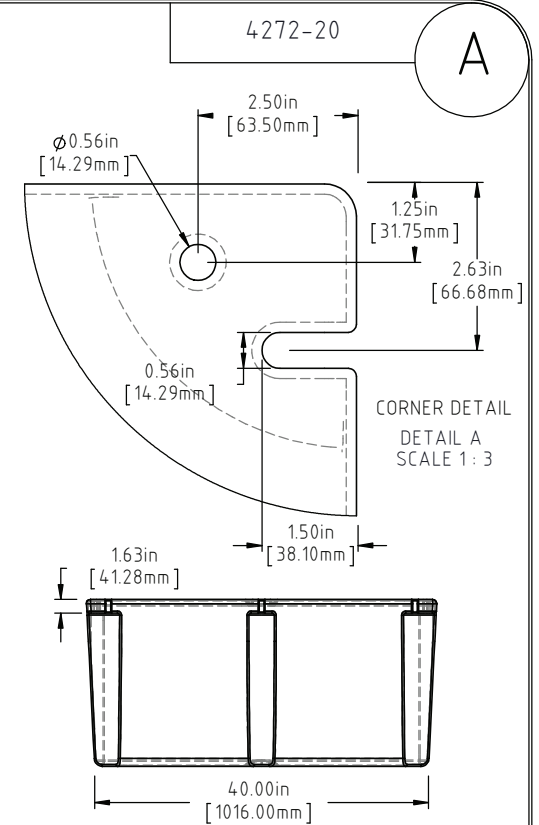
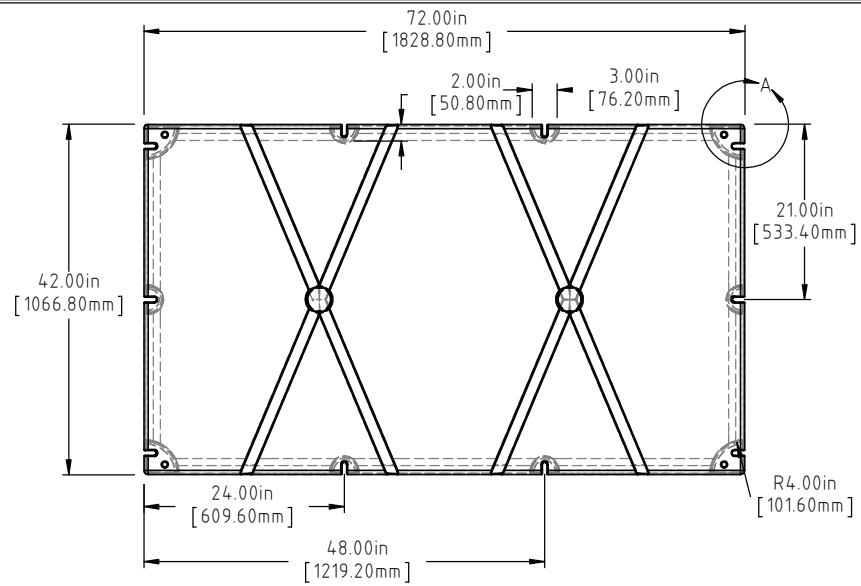

NOTE: BUOYANCY IS 1934 LBS. / 877KG)

				DRAWN / DATE ADH 12/11/13	MATERIAL POLYETHYLENE
A	BOTTOM AND SIDE VIEWS ADDED TO PRINT	ADH 12/4/14	2971	APPRD. / DATE REH 12/11/13	
REV	DESCRIPTION	BY / DATE	CCN		
ALL DIMENSIONS ARE IN DECIMAL INCHES TOLERANCES UNLESS OTHERWISE SPECIFIED		THIRD ANGLE PROJECTION ANSI 14.5M		SHOT WEIGHT: 60 LBS. (27.22 KG.)	NOTES: 1.) AF 60 LBS. (27.22 KG.) 2.) FF 98 LBS. (414246KG.) 3.) 0.160 IN (4.06 mm) NOM. WALL
POLYETHYLENE	METAL DECIMAL ± .125" FRACTION ± 1/4" ANGLE ± 1°			SHIPPING WEIGHT: SEE NOTES	
±1% @ 68°F				FINISH:	



Den Hartog
INDUSTRIES, INC.

Ace Roto-Mold Injection Molding Blow Molding Sowjoy

4010 HOSPERS DRIVE S. BOX 425, HOSPERS, IOWA 51238-0425

DESCRIPTION 42 X 72 X 20 FLOAT	
SCALE N.S.	PART NO. 4272-20